

35a Ireland Street

35a Ireland Street, Carnoustie, DD7 6AS

TOTAL AREA: 2050.06 sq ft • LIVING AREA: 1815.34 sq ft • FLOORS: 2



▼ Ground Floor

TOTAL AREA: 984.48 sq ft • LIVING AREA: 749.76 sq ft •

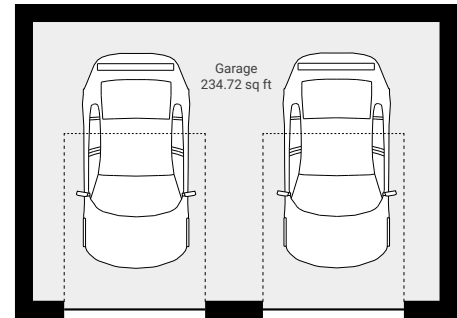
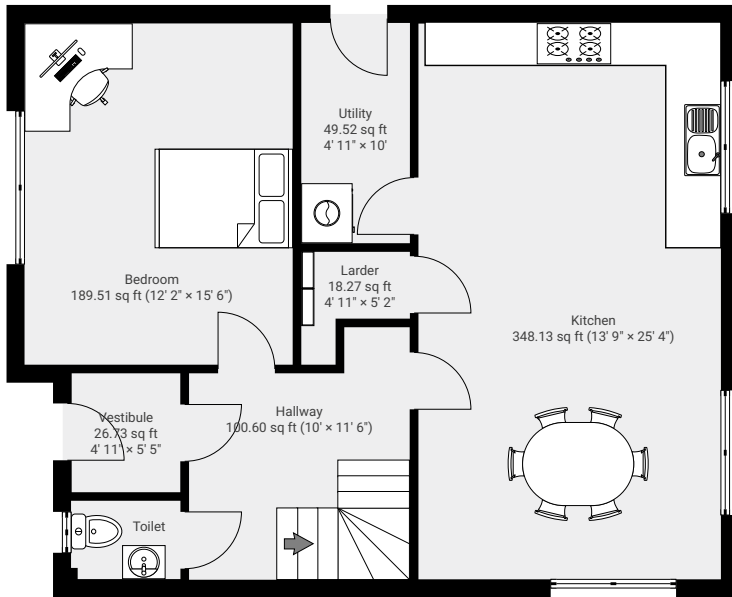

▼ 1st Floor

TOTAL AREA: 1065.58 sq ft • LIVING AREA: 1065.58 sq ft •

